

**MIDDLETON SOLAR**  
**SP02 and SP02-L**  
**SUNPHOTOMETER**  
**USER'S GUIDE**

Edition: SP02-V2.1

Date: Aug. 2024

---

© copyright 2024

CONTENTS		page
1	General	1
2	Construction	1
3	Installation	2
4	Maintenance	3
5	Adjustment	4
6	Technical Specification	5
7	Spare Parts	6
Appendix A. Circuit Board Connector		7
Appendix B. Tracker Mount Adaptor		8
Appendix C. Diopter Alignment Procedure		9
Appendix D. Accessory Shutter Mechanism		10

## 1 GENERAL

The Middleton Solar SP02 Sunphotometer has four narrow-bandpass spectro-pyrheliometers axially aligned in a sealed enclosure. The four channels operate simultaneously and the variation in channel-to-channel signal ratio, when the instrument is pointed directly at the sun, can give a fine-resolution indication of the spectral optical depth of the atmosphere. The SP02-L version is 35mm longer than the SP02 and has a narrower field of view to reduce light scatter from the sun aureole in locations that have a high aerosol load, such as northern Europe.

By fitting different bandpass filters in the four spectro-pyrheliometers the SP02 can be configured for measurement of total & aerosol optical depth, column ozone, or water vapour.

An accessory Shutter Mechanism is available for the SP02-L (see Appendix D).

## 2 CONSTRUCTION

The SP02 is a compact and light-weight instrument. It is machined from marine-grade aluminium that is hard anodised to provide a durable, weather-resistant finish. Figure 1 illustrates the instrument with one of the spectro-pyrheliometers shown in section. Each spectro-pyrheliometer channel has an independent low-noise signal amplifier with externally accessible gain adjustment. The four output signals range up to 4.5V fullscale.

Operating power requirement is modest and the instrument has an additional output to monitor internal temperature. Large diameter interference filters are used as these have better long-term stability than small filters.

Figure 1. Partial Sectioned View.

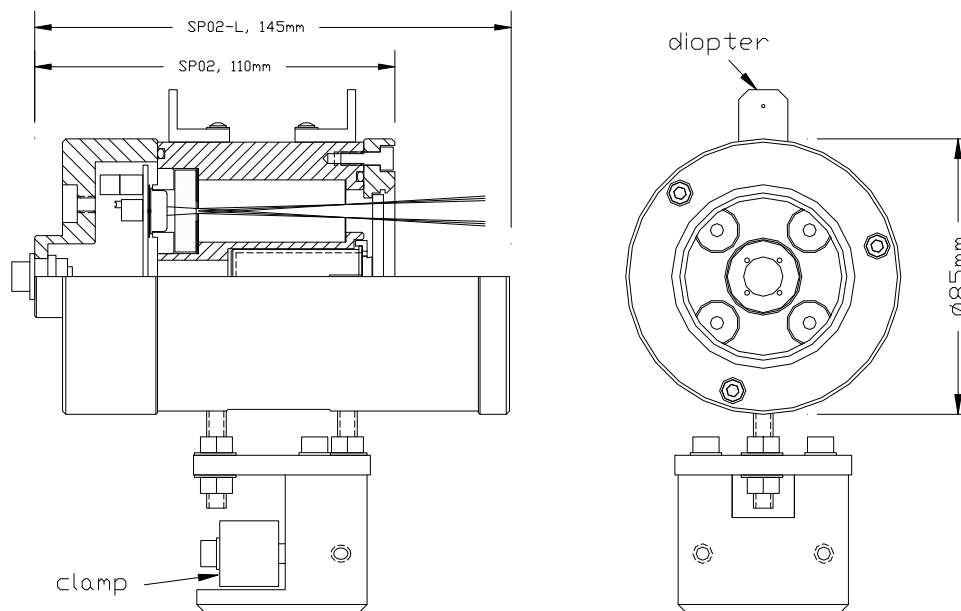

### 3 INSTALLATION

The SP02 power supply requirement is 5.5 to 14.5VDC, 20mA. It can be conveniently powered from any 6V, 9V, or 12V source such as a datalogger, small power supply, or battery. The circuit board includes a 200mA auto-resettable fuse to protect against short-term polarity reversal. Do not operate the instrument outside the specified voltage range.

The SP02 is supplied with a shielded eight-core unterminated output cable that plugs into the SP02 body. The cable shield should be grounded at the measurement end. The cable cores are:

Standard Cable		Low Temperature Cable
black	power supply negative	black
red	power supply positive (5.5 to 14.5 V)	red
white	channel A output	white
green	channel B output	green
yellow	channel C output	orange
violet	channel D output	red/black
blue	temperature output (10mV per °C. eg: 20°C is 0.20V)	blue
brown	output common	white/black

The measurement equipment should range up to 5V and have an input impedance of at least 1MΩ.

The power supply negative and the output common are connected on the circuit board via back-to-back diodes. Avoid ground-loop induced interference in your measurement setup by ensuring there is a single common ground point.

The power supply negative and the output common should be joined together at the measurement end of the system. If a single-ended data-logger is used then the output common should be grounded at the data-logger and this ground should return to power supply negative in the measurement setup. If a differential data-logger is used then the output common and power supply negative should be connected to the data-logger negative signal input.

It is recommended that the SP02 be mounted to a precision automatic sun tracker such as the Middleton Solar AST-02 or AST-03 Active Solar Tracker. The clamp on the SP02 body enables easy 2-axis adjustment. Poor alignment or inaccurate tracking may cause intermittent signal attenuation. See Appendix B for mounting adaptor for non Middleton Solar trackers.

Initial setup of the instrument involves verification of the pin-hole diopter alignment and adjustment of the sunphotometer channel gains. To check the diopter alignment, point the instrument towards the sun so that the Channel A response peaks, then confirm that the the pin-hole beam aligns with the cross on the rear of the diopter. See Appendix C for detailed alignment procedure. For gain adjustment see Section 5.

## 4 MAINTENANCE

Keep the glass window clean. Use only water and mild detergent to gently wash the surface.

The SP02 is hermetically sealed and contains a dessicant (non-toxic silica gel) to keep the interior dry and free from condensation. The condition of the silica gel can be viewed through the window. Fresh desiccant is orange, and exhausted desiccant is clear or green.

To gain access to the desiccant vial remove the three socket screws, shown in Figure 2, and separate the frontface from the instrument body. Pull the desiccant vial out of the body by its endcap. Refresh the silica gel and assemble in reverse order.

When refitting the frontface take care to locate the O-ring in its groove in the body before securing the three socket screws.

Figure 2. Front View of SP02

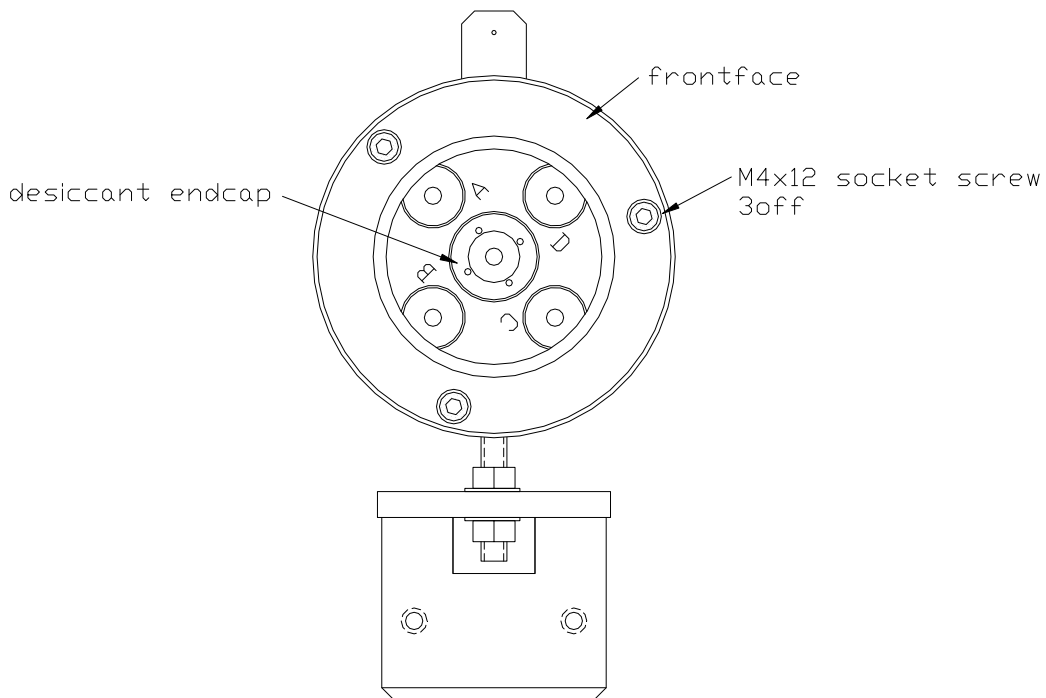

## 5 ADJUSTMENT

The SP02 Sunphotometer is not an absolute instrument and it can be calibrated using any recognised method for calibrating sunphotometers<sup>2</sup>.

The four spectro-pyrheliometer channels are identified on the front of the SP02 body as A, B, C, and D (see Figure 2). The output signal of each channel is factory set at a nominal value and can be easily altered<sup>3</sup>. Remove the plugs from the four ports on the backplate of the instrument to access the gain adjustment potentiometers (see Figure 3). Ensure the plugs retain their sealing washers. The gain potentiometers have 12-turns stop-to-stop and provide a linear gain span of approximately  $\pm 40\%$  from the mid-point.

Point the SP02 directly at the sun and use a small flat-blade screwdriver to adjust the gain potentiometers. Turn clockwise to increase gain. Always ensure the gain is such that the output signal does not exceed 4.5V under maximum solar radiation, as the amplifier circuitry saturates above this voltage.

Figure 3. Back View of SP02

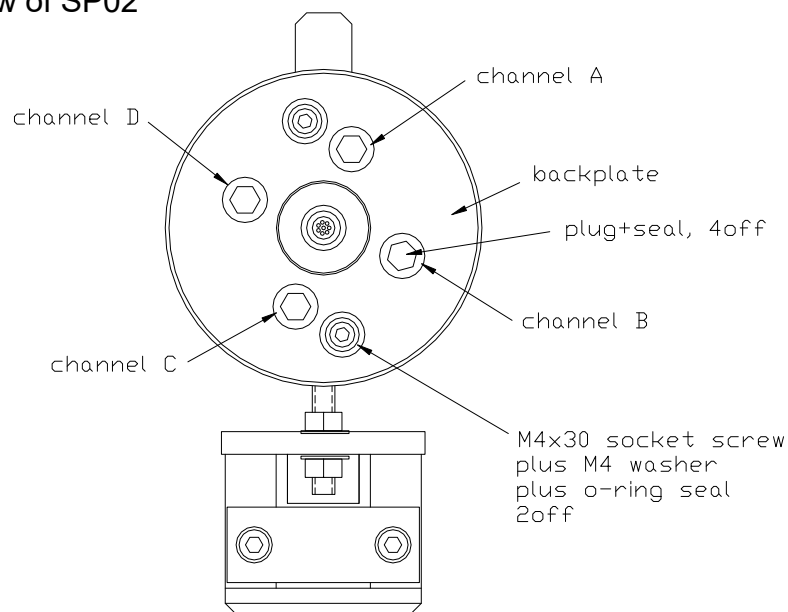

Two fixed gain ranges can be selected via link-plugs on the circuit board. A plug is present to select low range and removed to select high range. To access the link-plugs remove the two socket screws (Figure 3), and carefully separate the backplate from the instrument body; then unplug the output cable from the circuit board. When refitting the backplate take care to locate the large O-ring in the body. Also take care to locate a small O-ring between each washer (on socket screw) and the backplate. The four gain links are identified on the circuit board. LK1 is for channel A, LK2 for channel B, etc.

<sup>2</sup> eg: the Langley method, or the Comparison with Reference Instrument method

<sup>3</sup> typical factory output is 2V to 3V fullscale

## 6 TECHNICAL SPECIFICATION

SP02 optical geometry	field of view: 5.0° (2.5° opening angle) slope angle: 1.6° limit angle: 3.5°
SP02-L optical geometry	field of view: 2.5° (1.25° opening angle) slope angle: 0.7° limit angle: 1.8°
standard filters <sup>4</sup> : centre wavelength (10nm bandpass interference type)	aerosol version: 413, 500, 676, 860nm ozone version: 365, 500, 610, 780nm water vapour version: 500, 780, 810, 860nm
size; CWL tolerance	Ø25mm; ±2nm
blocking	> OD4, UV to far IR
filter non-stability (per year)	-2% (typical)
detector type; active area	UV si-photodiode; 33mm <sup>2</sup>
sensitivity gain setting x 4 channels	high/low by jumper; trim via 12-turn pot
output signal x 4 channels	-0.05 to +4.5 VDC max.
resolution	<0.005OD (Langley method)
response time	0.2s to 99%
operating temperature	-30°C to +70°C
power supply requirement	5.5 to 14.5VDC, 20mA
temperature output	10mV/°C (0.20V = 20°C)
desiccant	non-toxic silica gel, 8-10 mesh
output lead	5m, 8-core shielded cable with IP68 plug
mounting method	Ø25mm (1") female clamp, with adjustable alignment
weight (excluding 0.5Kg lead)	SP02: 1.25Kg SP02-L: 1.75Kg

The SP02 has negligible temperature error, in the range 350-930nm because the si-photodiode detector used has a thermal coefficient of zero in this range and the interference filters used have very small thermal coefficients (0.016-0.023nm/°C).

---

<sup>4</sup> Alternative filters in the range 350 to 930nm , 10nm bandpass, can be specified.

## 7 SPARE PARTS

Spare parts may be ordered from the manufacturer or through an approved distributor. Part names and numbers are shown on Figure 4; please quote both when ordering. It is also important when ordering parts to include the Serial Number of the instrument, this is inscribed on the identification label on the body. The label also lists the filters fitted to channels A, B, C, and D.

Figure 4. SP02 & SP02-L Spare Parts

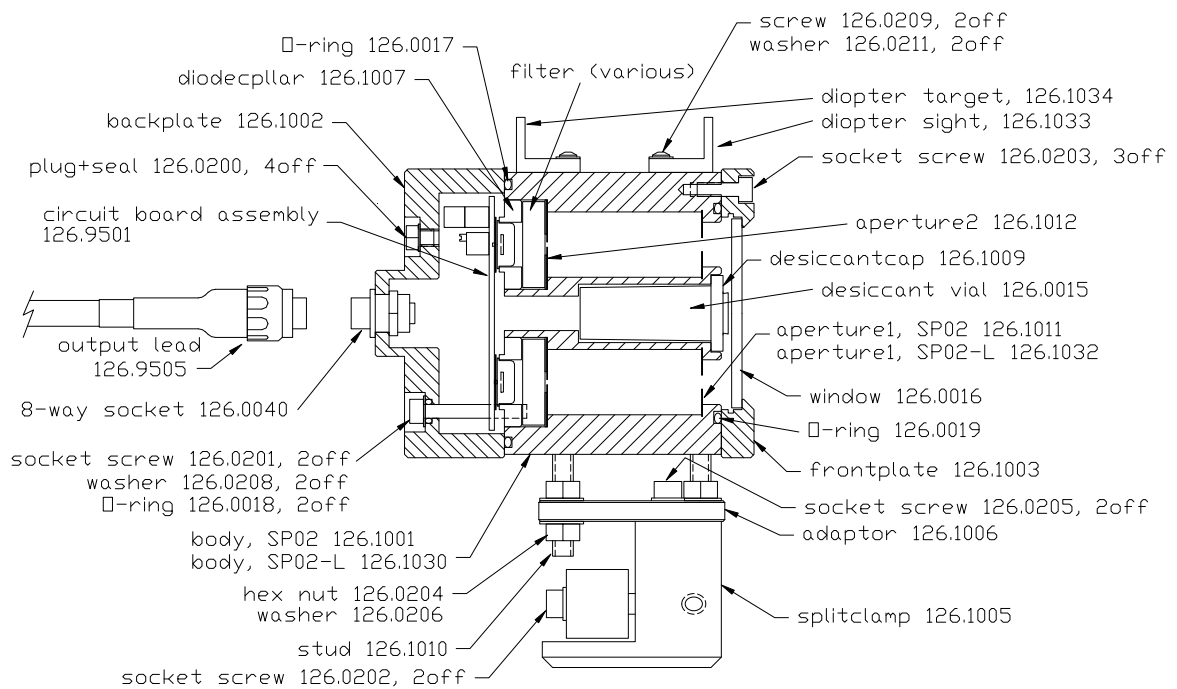



## Appendix A. Circuit Board Connector

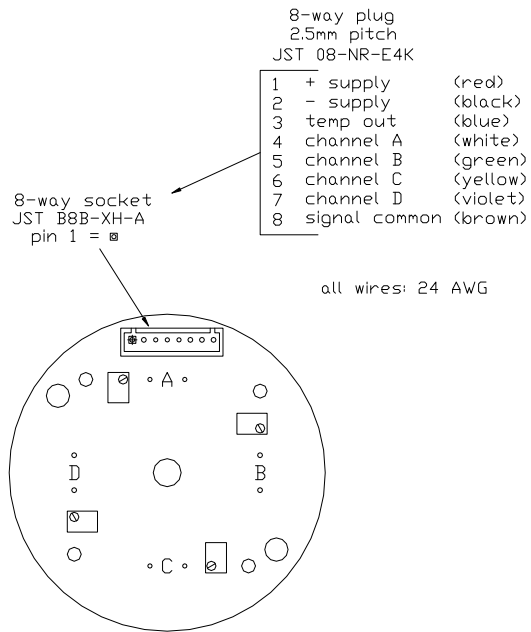

## Appendix B. Tracker Mount Adaptor (for non Middleton Solar Trackers)

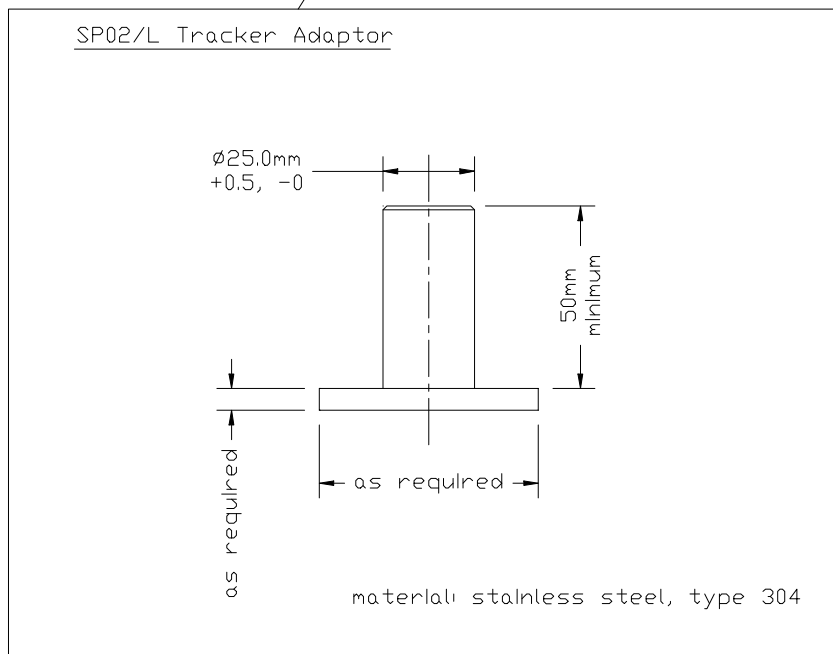
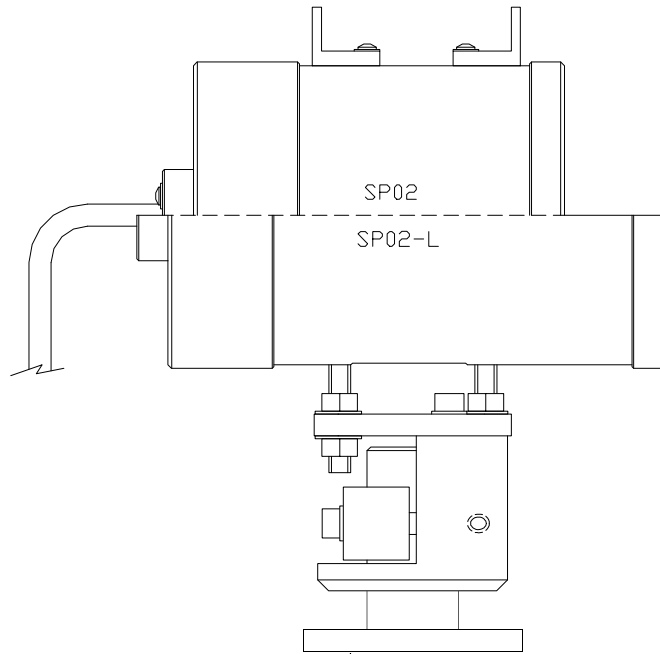

## Appendix C. Diopter Alignment Procedure

Follow this procedure to align the diopter of an SP02 or SP02-L:

- 1) install the SP02-L on the horizontal axis of a precision Solar Tracker (preferably an active tracker such as the Middleton Solar AST-02 or AST-03);
- 2) ensure the Tracker is exactly tracking the clear sun (no clouds or haze), approximately at solar noon;
- 3) the SP02-L must be mounted to the Tracker with its original splitclamp, so alignment adjustment can be easily made;
- 4) monitor the signal from channel A of the SP02/L with an accurate voltmeter (signal should be approximately 2V);
- 5) loosen the splitclamp and manipulate the SP02-L about the horizontal axis of the Tracker to find the peak signal on channel A;
- 6) mark the diopter with a horizontal line (use pencil) at the peak signal location, and tighten the splitclamp to the Tracker axis;
- 7) loosen the M6 nuts that hold the splitclamp to the two threaded rods on the SP02/L body;
- 8) tighten/loosen the nuts to manipulate the SP02-L about the vertical axis of the Tracker to find the peak signal on Channel A;
- 9) mark the diopter with a vertical line at the peak signal location, and tighten the nuts to secure the splitclamp to the rods;
- 10) repeat 4) to 9) until you are confident the alignment is correct, and then make a permanent alignment mark on the diopter target where the two pencil lines intersect.

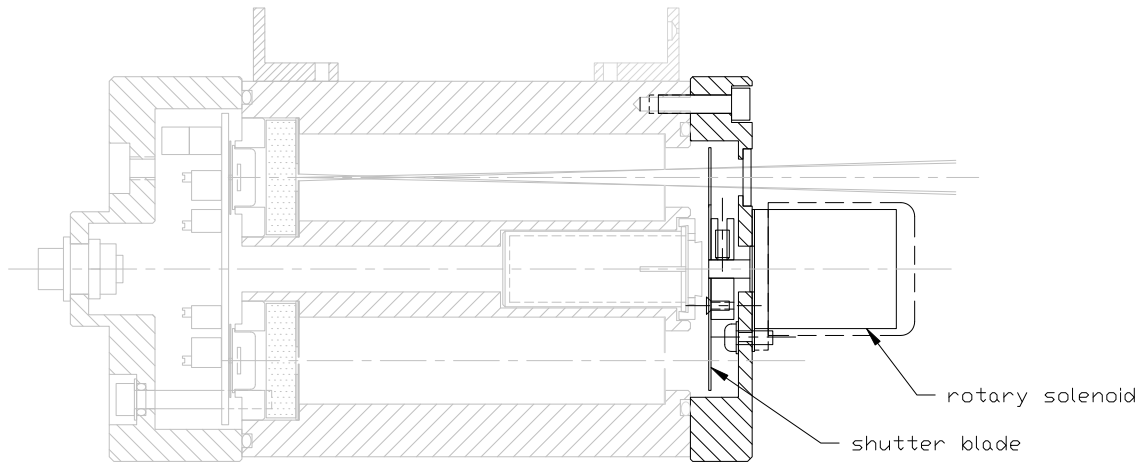
**Appendix D. Accessory Shutter Mechanism (for SP02-L)**

The accessory Shutter is an electromechanical mechanism to regulate the light entering a Middleton Solar SP02-L Sunphotometer. The Shutter replaces the standard Window Plate of the SP02-L. It contains a shutter-blade, actuated by a bi-directional solenoid. The rotary-solenoid is driven from a Control Box that accepts contact-closure commands to Open, or to Close. The commands can originate from manually operated push-switches, or can be programmed from a Data Acquisition System. The Shutter operates simultaneously on all four Sunphotometer channels.