

USER'S GUIDE
for
MIDDLETON SOLAR
AST-02 AST-03 AST-03T
ACTIVE SOLAR TRACKING SYSTEM

Version: 3.3



CONTENTS		page
1	General Description	1
2	Installation & Setup	2
3	Operation	5
Appendices		
A	Tracker Control States	6
B	Status Indicator Table	7
C	Instrument & Accessory Installation Example	8
D	General Specification	9
E	Dimensions	10
F	Shade Arm Operating Area	11
G	Status Output Lead option	12
H	Serial Data Port (USB) option	13
I	Elevation Control Lead (AST-03T only)	14
J	Spare Parts	15

1. GENERAL DESCRIPTION

The Middleton Solar AST-02/3/3T is a 2-axis active sun tracking system for solar instruments used to measure direct and diffuse irradiance. The AST-02 has a single horizontal elevation shaft. The AST-03 has two coaxial elevation shafts mechanically locked together, and the AST-03T version has two coaxial elevation shafts that are controlled separately to facilitate shade/un-shade and alignment testing (see Appendix I).

The horizontal and vertical shafts of the AST-02/3 are rotated by stepper motors connected to harmonic gearheads; the AST-03T has two horizontal drive motors. The harmonic gearheads have zero-backlash so there is no motion hysteresis, and the shafts have a sensor to indicate absolute rotary position. The AST-03T also has dual micro-electromechanical inclinometers to enable elevation shaft coordination. An Eye is attached to one horizontal arm. The Eye contains a quadrant photodetector that provides precise information about sun displacement relative to where the Tracker is pointing. The spectral response is confined to a 10nm bandwidth of near-infrared radiation so that the Eye reacts only to clear sun and does not respond when the sun is bright but hazy and its position uncertain. The response threshold varies with sun elevation so precision is preserved even when the sun is very close to the horizon where the sun intensity is relatively low.

An included GPS module is used to automatically configure the Tracker for the geographic location of the site and to set the in-built computer to precise local time. The default operation is real-time active tracking with the Eye locked onto the sun. When the sun is obscured (by clouds) the system reverts to open-loop passive tracking using GPS position information. As soon as the sun is detected by the Eye the system actively tracks the sun under closed-loop control, and any accrued passive position error is corrected. The Tracker halts shortly after sunset, then at night traverses to the dawn position ready to resume tracking.

The Tracker operates on 12VDC and has low power consumption so it is suitable for solar powered sites. The User interface consists of a single Status light to provide information about the normal operation of the Tracker and also indicate warning or error states.

Available options include:

- LP01 Levelling Plate
- TA01 Extended Elevation Shaft, 150mm (for AST-02, with SA02 fitted)
- PM02 (single), PM04 (dual)
- ME01 Elevation Inclinometer
- SA02 Shadearm Assembly & Platform; SA02-T version, 2 shade disks
- Status Output Lead (Appendix G); Serial Data Port (Appendix H)
- Extended cable length, up to 25m
- Extended temperature range, -40 to +80°C

Middleton Solar radiometers that are suitable for the AST-02/3/3T Tracker include:

- DN series Pyrheliometers; SP02/L Sunphotometers
- EQ & ER series Pyranometers; PG series Pyrgeometers

2. INSTALLATION & SETUP

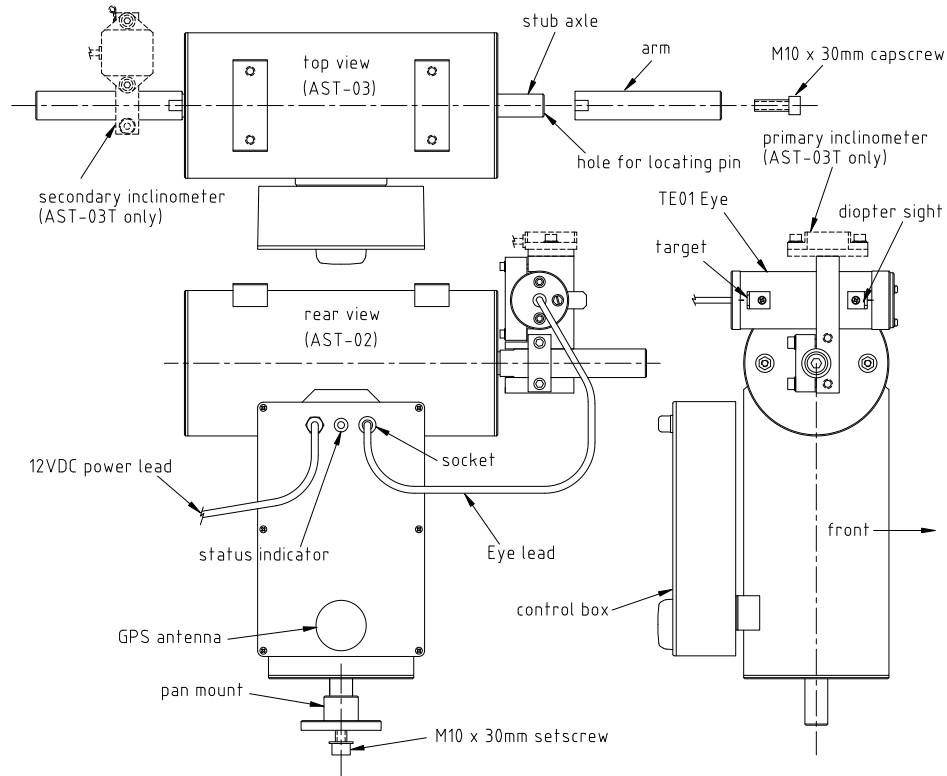

Setup should be undertaken at or near solar noon, the sun must be clearly visible, and the GPS antenna must not be obscured.
Setup must proceed in the sequence described.

A) Unpack the Tracker.

B) Attach the arm(s) to the horizontal stub axle(s) with the M10 capscrew(s).

A locating pin inside the arm must align with a hole in the stub axle.

Tools required: 8mm AF hex key (for capscrew);
23mm AF spanner (for arm).

Firmly tighten the capscrew while holding the arm with the spanner.

C) Place the Pan Mount on a level platform that has a 10mm hole

The platform must be level.

Pass the M10 setscrew, with washer, up through the platform hole & Pan Mount. Place the vertical stub axle into the Pan Mount, and loosely secure it with the M10 setscrew.

A locating pin inside the Pan Mount must align with a hole in the stub axle. Do not fully tighten the setscrew until step (H) below.

D) Attach the TE01 Eye to the right-hand arm (when looking at the Control Box).

Note: Eye on AST-03T has the Primary Inclinometer included.

The orientation of the Eye is important; position it as illustrated; above the arm and facing the front, with a 10mm gap to the Gearbox.

Loosely secure the two M6 capscrews of the Eye clamp.

Do not fully tighten the clamp until step (H) below.

Tools required: 5mm AF hex key (for clamp).

Plug the Eye lead into the socket on the Control Box.

- E) AST-03T ONLY: Attach the Secondary Inclinometer to the left-hand arm
The orientation of the Inclinometer is important; position it as illustrated; above the arm and facing the front, with a 40mm gap to the Gearbox. Loosely secure the two M6 capscrews of the Inclinometer clamp.
Do not fully tighten the clamp until step (H) below.
Tools required: 5mm AF hex key (for clamp).
Plug the Primary and Secondary Inclinometer leads into the side of the Control Box.
Do not connect the Elevation Control Lead to the Control Box.
- F) Cover the Eye window with aluminium foil to block any sunlight.
Connect the power lead to a 12 volt DC; red core to +ve, blue to –ve. The pan motor will operate to move the Tracker to a nominal North/South orientation, then the tilt motor(s) will operate to move the Eye (and the AST-03T Secondary Inclinometer) to a nominal horizontal orientation. Pan & tilt movement will then pause while a search for the GPS signal is performed.
For the AST-03T, DISCONNECT THE POWER as soon as the Secondary Inclinometer has halted. Then set both the Eye and the Secondary Inclinometer to be horizontal and tighten their clamps¹.
Re-connect the power.
The status indicator will loop <on 2 seconds, off 2 seconds> until the GPS signal is found.
The initial GPS signal search may take up to 15 minutes.
The typical GPS search time is 15 seconds to a few minutes.
If no GPS signal is available the setup can not proceed further.
In this case try again later as temporary atmospheric conditions may have attenuated the GPS signal.
- G) When the GPS information has been obtained the Tracker will tilt and pan until it has moved to the local sun position².
Although the Tracker is not yet aligned, it will commence to move as if passively tracking the sun.
The status indicator will loop <on 3 seconds, off 1 second>.
- H) Manually pan the Tracker & tilt the Eye, to aim the Eye directly at the sun. Do not force the Tracker axles to rotate (loosen their clamp screws).
The Eye alignment is correct when the sun spot from the Diopter Sight is on the cross lines of the Target.
Tighten the two M6 capscrews of the Eye Clamp.
Tighten the M10 setscrew of the Pan Mount.
For the AST-03T, re-position the Secondary Inclinometer to be at the same tilt angle as the Eye (to maintain synchronization).
Uncover the Eye window.
The Tracker will read the Eye signals and then pan & tilt slightly to lock the Eye onto the sun.
The Tracker will now actively track the sun.

¹ This will enable Primary and Secondary Inclinometers to synchronize

² Some firmware versions may proceed to apparent dawn position before local sun position

The status indicator will be <on continuously>.
During active tracking the Passive Azimuth (pan) & Passive Zenith (tilt) positions are continuously synchronised to the actual local sun position.

I) Repeat steps (F) to (H) to verify the set-up is correct.

J) Ensure the Control Box leads cannot restrict the movement of the Tracker.
The Tracker can range up to 500° in pan.

K) Fit instruments and accessories to the Tracker.
Take care not to exceed the torque and payload capacities of the Tracker (see Appendix D).
Allow sufficient operating area if optional SA02 Shading Arm Assembly is used (see Appendix F).

3. OPERATION

The initial installation and setup is described in Section 2.

Once setup is completed the Tracker will operate continuously so long as the power is not disconnected. See Appendix I for information on elevation control for the AST-03T model.

Whenever the power-up occurs the Tracker will sequence through:

- pan to orient the Tracker to North/South;
- tilt to orient the Eye to horizontal (also secondary tilt for AST-03T);
- pause and search for the GPS signal;
- tilt then pan to point the Eye at the sun;
- commence tracking.

For Normal Operation the Status Indicator will display one of these conditions:

- loop <on 2 seconds, off 2 seconds> = start-up and search for GPS;
- loop <on 3 seconds, off 1 second> = passive tracking, no-sun;
- steady <on continuous> = active tracking, locked onto sun³.

The GPS information, and AST-03T tilt axis synchronization, is checked each night at 12:15am. Tracking will pause up to 25 minutes during this procedure.

For Operation Warning the Status Indicator will display one of these conditions:

- loop <on 3 seconds, flash x 2> = Eye disconnected, or faulty;
- loop <on 3 seconds, flash x 5> = GPS signal not available;
- loop <on 1s, off 3s, looping = Elevation axis sync. (AST-03T only).
- loop <on 6 seconds, flash x N> = N days since last active tracking
More than 8 days is not indicated (eg: N=8, for all days > 8);

The Tracker will continue to operate during a warning condition, but correct tracking alignment is not assured. The User should identify the cause of the warning and take corrective action if necessary. The Eye warning can occur if the Eye clamp is loose, or if the Pan Mount is loose, or the axle locating pins are not seated. In this case disconnect the power to reset the Eye warning, then reconnect the power and repeat the setup alignment procedure.

For Operation Fault the Status Indicator will display this condition:

- loop <flash every 1 second> = hardware error, tracking halted.

The Tracker will stop operating if a fault condition occurs. In this case re-start the Tracker to determine if the fault condition persists. If the fault persists it is likely that a motor has failed, or a rotary position sensor has failed or is out-of-range⁴. The User should have the Tracker inspected and repaired. The most recent 20 minutes of Tracker operation is logged in internal memory to assist in fault diagnosis⁵.

³ Also <on continuous> during start-up when moving from Home position to Local position.

⁴ An out-of-range position sensor will halt motor operation regardless of control commands. This feature is a fail-safe limit stop to prevent self-harm.

⁵ Contact Middleton Solar if you require access to the internal datalog file.

APPENDIX A. Tracker Control States

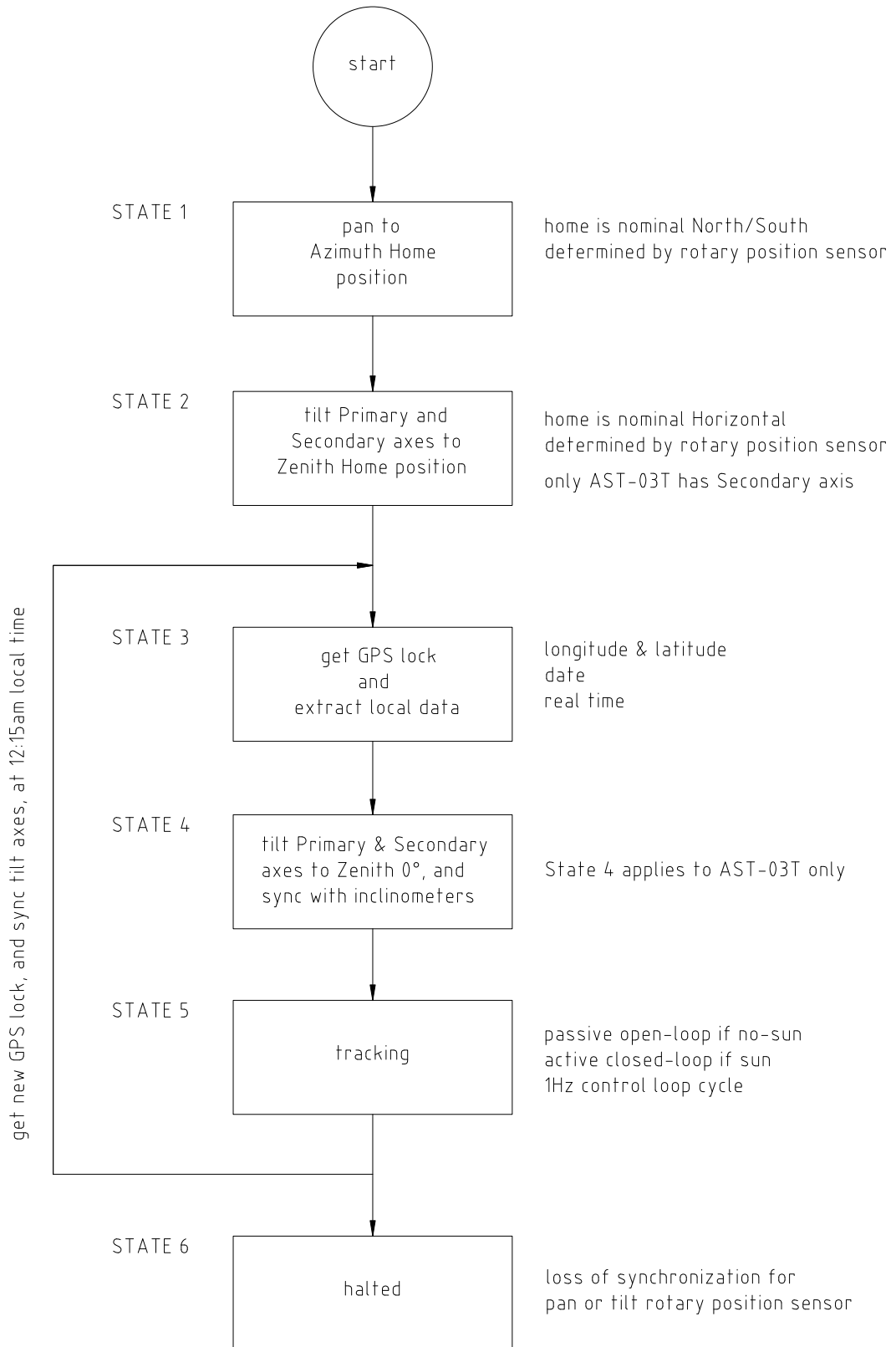

APPENDIX B. Status Indicator Table⁶

#	Indicator	display priority	Status	Comment
-	off	-	power not connected	-
F1	on, flashing at 1Hz continuous	1	hardware error: tracking halted	Pan or Tilt position error > 8°; or out of range; or Motor fault
W1	on 3s, flash x 2, looping	2	Eye warning: passive tracking continues	Eye unplugged; or Eye faulty; or active to passive difference > 10°
W2	on 3s, flash x 5, looping	3	GPS warning: passive tracking continues	GPS fault, or Antenna obscured
W3	on 6s, then flash x N, looping	4	misalignment warning: N is days since last Active Tracking	Tracker or Eye misaligned; or sky overcast. N max = 8 days
W4	on 1s, off 3s, looping	5	(AST-03 ONLY) Elevation Axis Sync Warning: secondary axis halts, Tracking continues	Primary or Secondary Inclinometer is loose, jammed, unplugged, or faulty
N3	on, continuous	6	active tracking, Eye locked onto sun	also during Home to Local move at start-up
N2	on 3s, off 1s, looping	7	passive tracking, with GPS	Eye connected but no sunshine; or Eye is not correctly oriented (upside down)
N1	on 2s, off 2s, looping	8	start-up & GPS search	may take 15 min.

Normal conditions are N1, N2, N3.

Warning conditions are W1, W2, W3, W4

W4 is for AST-03T Tracker only.

Fault condition is F1.

A higher priority display status will usually override a prior lower priority status.

Supply power must be disconnected, then reconnected, to reset W1 Eye warning.

⁶ table is valid from S/No. 1078; status #5 to #8 differ up to S/No. 1077

APPENDIX C. Instrument & Accessory Installation Example, for AST-03T

TOP VIEW, with direct sun instruments & inclinometers

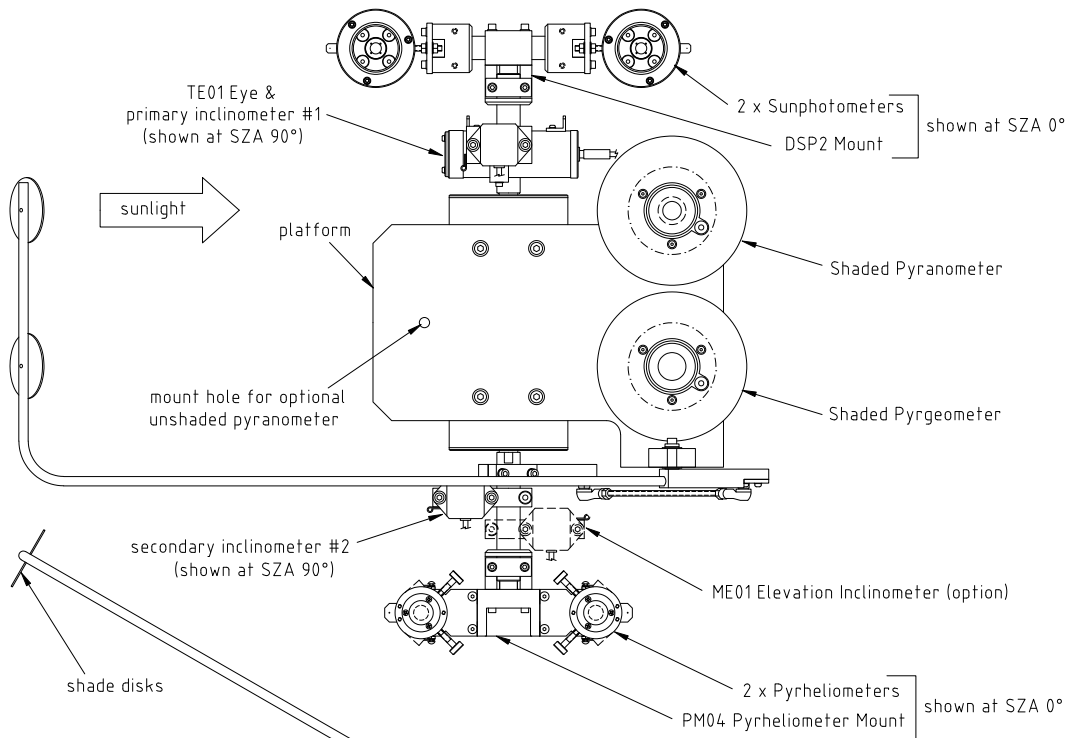

Sun, Arm, Eye shown at SZA 60°

SA02-T Shading Arm Assembly

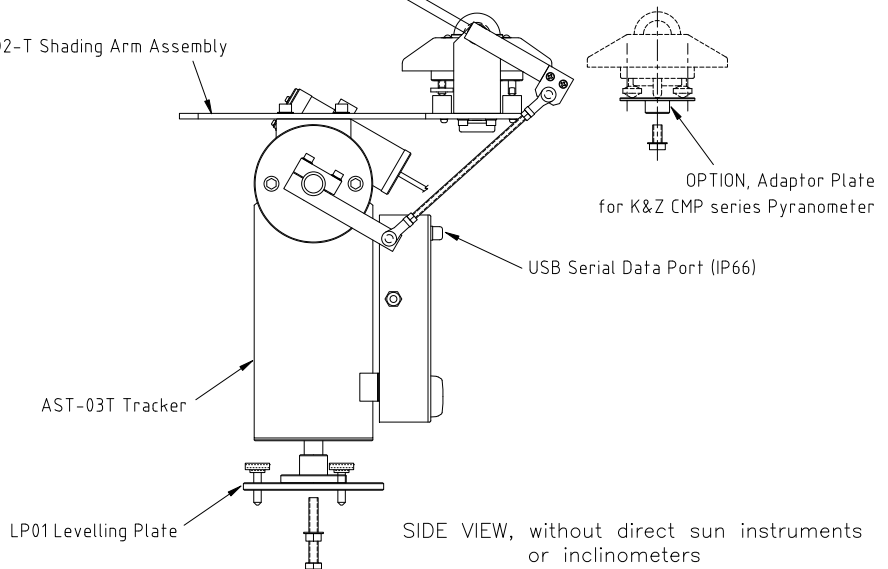

SIDE VIEW, without direct sun instruments or inclinometers

APPENDIX D. General Specification

drive mechanism	direct harmonic gearing, zero backlash
motor	stepping motor (AST-02/3 = 2, AST-03T = 3)
elevation shaft	Ø25 x 130mm (AST-02 = 1, AST-03/3T = 2)
active tracking	quadrant Eye, real-time closed-loop control
active sunshine threshold	automatically varies with solar zenith angle
operating temperature	-30 to +60°C
power requirement	12V DC nominal (11-16VDC) AST-02 & AST-03 <10W continuous AST-03T <20W
power lead	2-core, 6m, with connector at Tracker end
control method	in-built computer controller & firmware; GPS receiver
user interface	status indicator LED; available USB port
elevation control (AST-03T only)	3 x TTL inputs: 4 standard commands; 3 user defined
shaft coordination (AST-03T only)	MEMS Inclinometers on both elevation shafts
construction	marine grade aluminium & stainless steel O-rings & lip seals
sealing	IP 65, all-weather
weight (standard configuration)	AST-02 = 10Kg; AST-03/3T = 12kg
shipping size & weight	47x43x28cm; AST-02 = 12kg; AST-03/3T = 14kg
standard configuration	Tracker Gearbox & Control Box, and TE01 Eye
available options	LP01 Levelling Plate TA01 Extended Elevation Shaft, 150mm PM02 Pyrheliometer Mount (single) PM04 Pyrheliometer Mount (dual) ME01 Elevation Inclinometer SA02 Shadearm Assembly & Platform SA02-T Shadearm with two shade disks Status Output Lead (TTL or RS232) Serial Data Port (USB) & Lead Extended cable length, up to 25m Extended temperature range, -40 to +80°C

AST-02 type can accommodate either SA02/T or PM02/4 options.

AST-03/3T type can accommodate both SA02/T and PM02/4/options.

APPENDIX E. Dimensions

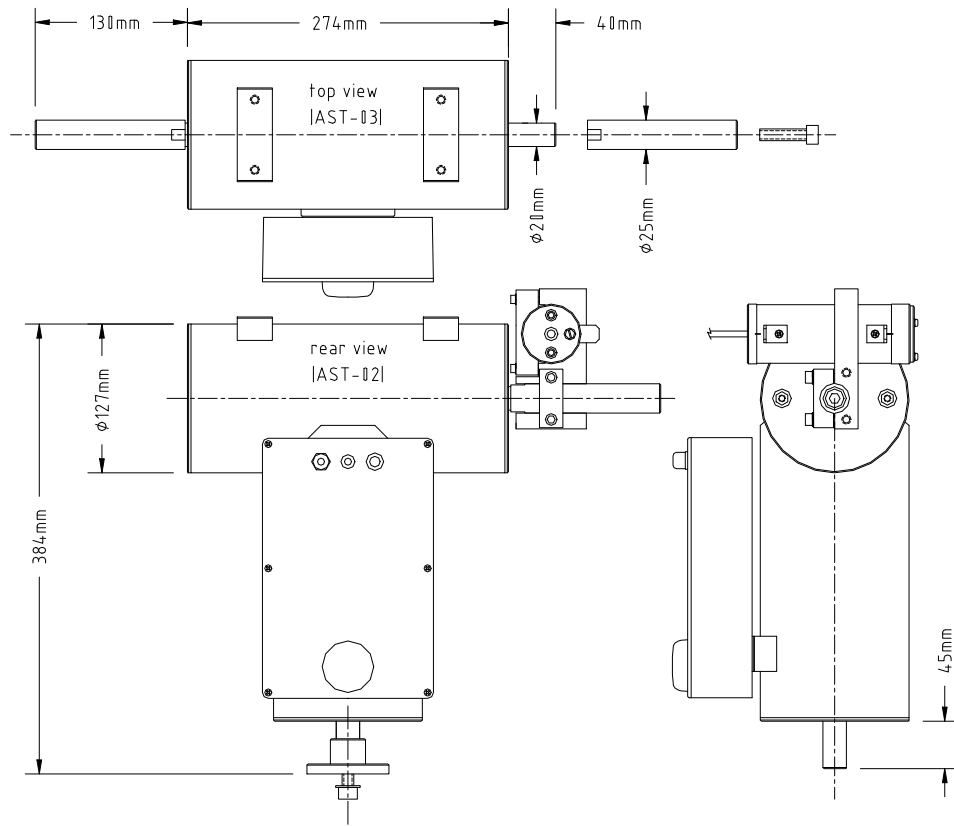

APPENDIX F. Shade Arm Operating Area

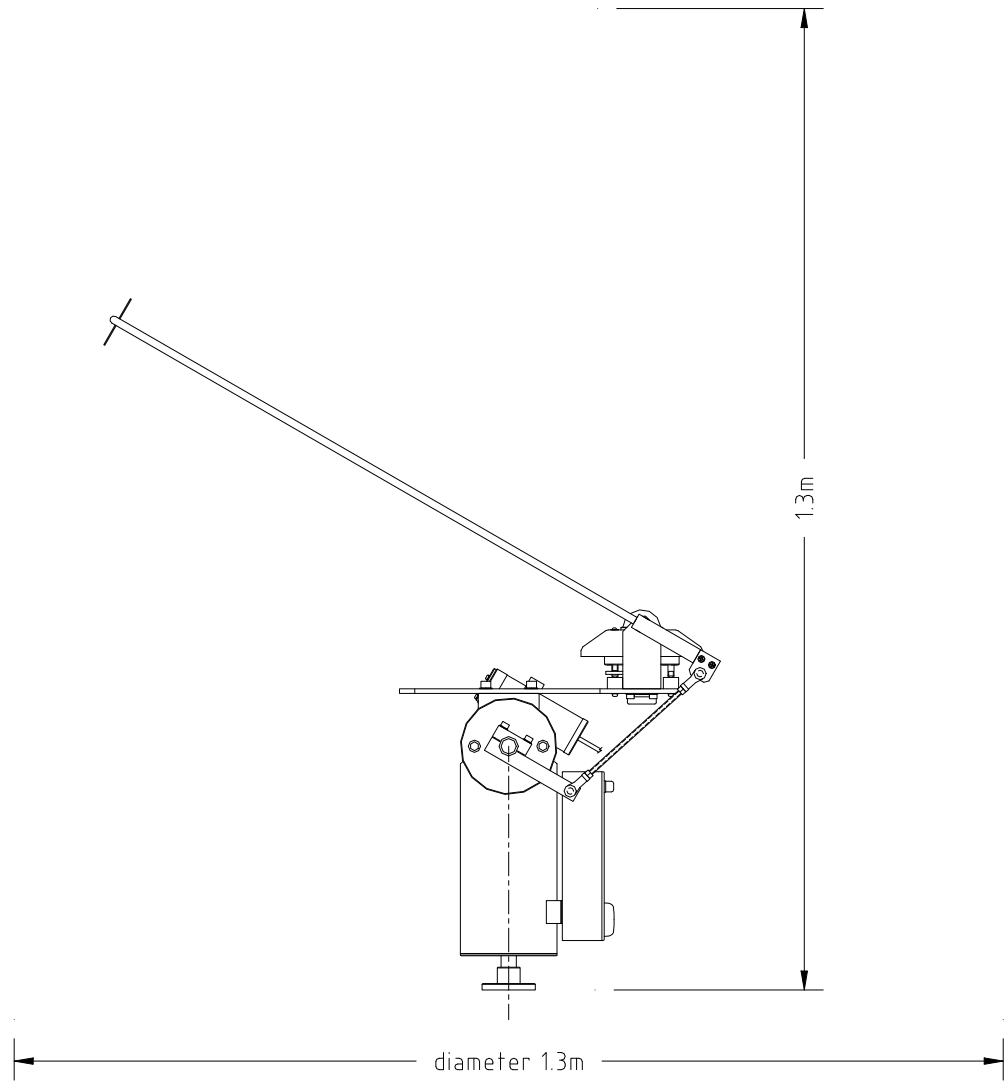

APPENDIX G. Status Output Lead, TTL or RS232

An optional Status Output lead is available in TTL type or RS232 type. This lead is factory fitted during Tracker manufacture. It is not available if the Serial Data Port option (Appendix H) has been installed.

The Status Output Lead is identified with a *YELLOW* marker sleeve.

TTL Type Status Output Lead⁷

This lead provides three TTL outputs which, in combination, show the same states as the Status Indicator light that is on the Tracker (see Appendix B). In the case of an unattended Tracker the TTL Status Outputs facilitate remote monitoring of Tracker behaviour.

Status priority	#	output 0	output 1	output 2	Status
0	-	Lo	Lo	Lo	no power
1	F1	Hi	Hi	Hi	hardware fault
2	W1	Hi	Lo	Hi	Eye warning
3	W2	Lo	Hi	Hi	GPS warning
4	W3	Hi	Hi	Lo	alignment warning
5	N3	Hi	Lo	Lo	active tracking
6	N2	Lo	Hi	Lo	passive tracking
7	N1	Lo	Lo	Hi	start-up & GPS search

Lo = TTL output low (0V to 0.8V)

Hi = TTL output high (2V to 5V)

The wire cores of the TTL Status Output Lead are:

Black wire = status output 0

White wire = status output 1

Yellow wire = status output 2

Green Wire = status output common

RS232 Type Status Output Lead

This lead provides access to a continuous RS232 stream of 26 internal Tracker control parameters, in CSV format, updated every second. This status output is not intended for the typical User; please contact Middleton Solar if you require further information.

⁷ TTL, Transistor – Transistor Logic

APPENDIX H. Serial Data Port (USB)

An optional Serial Data Port is available. This is factory fitted during Tracker manufacture. It is not available if the Status Output Lead option (Appendix G) has been installed.

A sealed micro-USB Socket, fitted to the Control Box Lid, is directly connected to the internal Tracker Control Computer.

An external computer can be linked to the Serial Data Port to enable access to Tracker set-up and data-stream, using third-party programmes such as PuTTY.⁸

Control Firmware upgrades provided by Middleton Solar can be uploaded via an external computer, linked to the Serial Data Port, using third-party programmes such as chip45boot2.⁹

The Serial Data Port is not intended for the typical User; please contact Middleton Solar if you require further information.

⁸ PuTTY is a free open-source terminal emulator, serial console, and file transfer application.

⁹ Chip45boot2 is a free PC/Windows bootloader application with a graphical user interface.

APPENDIX I. Elevation Control Lead (AST-03T Tracker only)

The AST-03T tracker has two coaxial elevation/tilt shafts. The Right Hand¹⁰ shaft is controlled by the Eye and the Left Hand shaft can be controlled by commands defined by a combination of three TTL inputs.

The AST-03T has a MEMS (Micro-ElectroMechanical System) inclinometer on each elevation shaft to enable precise coordination of the relative rotary position.

The default condition is zero elevation offset so the AST-03T behaves the same as an AST-03 (with locked elevation shafts)¹¹.

The Elevation Control Lead is identified with a *BLUE* marker sleeve. The wire cores of the Elevation Control Lead are:

- Red wire = input 1
- Yellow wire = input 2
- Blue wire = input 3
- Green Wire = input common

Table of Elevation Shaft Commands

#	Input 1 (red)	Input 2 (yellow)	Input 3 (blue)	Command
0	Hi	Hi	Hi	zero elevation offset
1	Lo	Hi	Hi	1° elevation offset
2	Hi	Lo	Hi	2° elevation offset
3	Lo	Lo	Hi	3° elevation offset
4	Hi	Hi	Lo	10° elevation offset
5	Lo	Hi	Lo	available for User defined command
6	Hi	Lo	Lo	available for User defined command
7	Lo	Lo	Lo	available for User defined command

Lo = TTL low (0V to 0.8V) = Input wire connected to green wire
 Hi = TTL high (2V to 5V) = Input wire isolated
 an offset means a decrease in elevation angle

To activate a Command: connect the relevant input wires (red, yellow, or blue) to the green wire. Do not connect external power to the wires. Command activation can be readily integrated into 'Data Acquisition and Control' relay outputs.

The default condition, when the Elevation Control Lead is not connected to the Tracker, is Command #0 (zero elevation offset). A Command will be enacted only when the previous Command has been completed.

Commands 0,1,2,3 can be used for alignment testing of direct sun instruments. Command 4 can be used for shade/unshade testing of pyranometers.

Commands 5,6,7 are available for other offsets, in the integer range 0 to 15°. The optional Serial Data Port is required to configure Commands 5,6,7 (see Appendix H).

¹⁰ Right Hand, and Left Hand, are defined with User facing the Tracker Control Box

¹¹ during the start-up routine the elevation shafts are not locked and operate sequentially

APPENDIX J. Spare Parts

The Tracker is modular in construction to simplify in-field servicing. Components and modules may be ordered from the manufacturer or through an approved distributor. The component/module name and part number is shown in the illustration below. Please quote both when ordering. It is also important when ordering parts to include the Model & Serial Number of the Tracker; these appear on an identification label on the Tracker body.

